

TOP 5

Chemical Applications



deutsch
english
español
portuguese
Русский язык
中国

TOP 1 Halogen Concentration

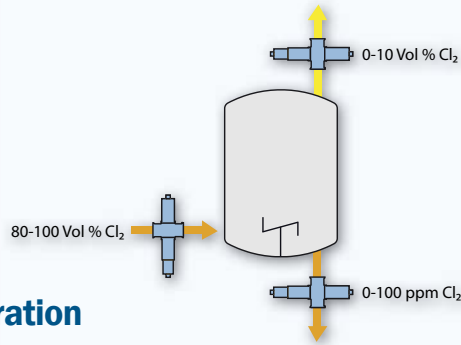

TOP 2 Filter Control

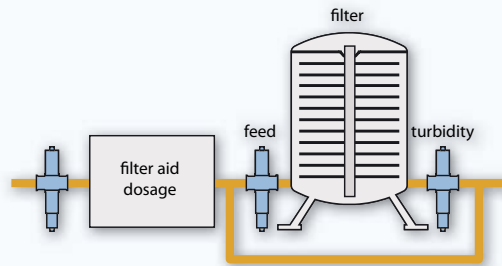

TOP 3 Color and Concentration

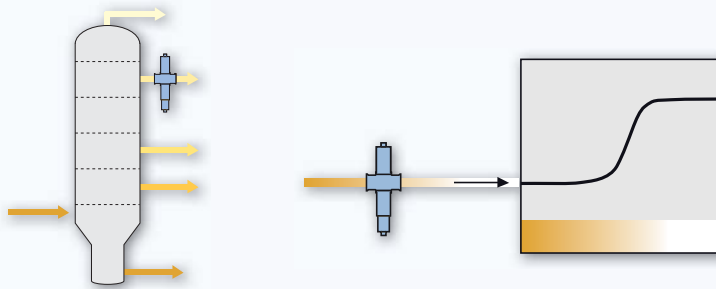

TOP 4 Condensate and Cooling Water

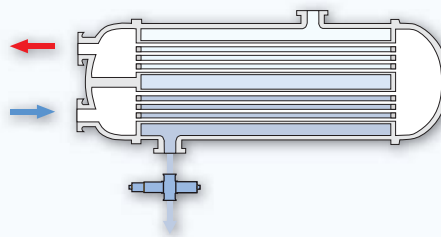

TOP 5 Phase Separation

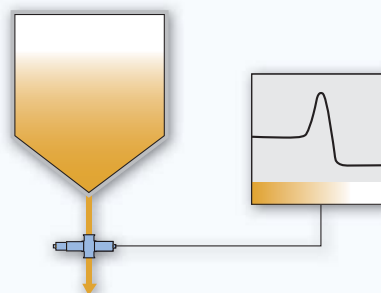

Acetaldehyde
Acetone
Alcohol, Water in
Acrolein
Acrylic Acid
Activated Carbon
Aldehyde
Ammonia
Aniline
APHA
Aromatics
ASTM
Benzene
Benzaldehyde
Benzyl Chloride
BTEX
Bisphenol A
Bromine
Caffeine
Chemical Nickel
Chlorine
Chlorobenzene
Chlorine Dioxide
Chlorophyll
Chromate
Cobalt
COD
Color
Copper
Cresol
Dichromate
Ethylbenzene
Fluorine
Gardner®
Hazen
Hydrogen Peroxide
Hypochlorite
Iodine
Iron
Ketones
Lime Water
Latex
MDI/MDA
Monochloro Benzene (MCB)
Naphtalene
Nickel
Nitrobenzene
NO_x
Oil in Water
Ozone
Palladium
Peracetic Acid
Permanganate
Phenol
Phosgene
Phthalic Acid
Platinum
Pyridine
Sulfur Dioxide
Styrene
Suspensions
TDA
Titanium Dioxide
Toluene
TOC (SAK 254)
Turbidity
UV-Absorption
Water Concentration
Water in Oil
Water in Fuel
Xylene

and many more...



Content

TOP 5 Chemical Applications

TOP 1 Halogen Concentration 04

TOP 2 Filter Control 06

TOP 3 Color and Concentration 08

TOP 4 Condensate and Cooling Water 10

TOP 5 Phase Separation 12

Principles of Measurement 14

Additional Benefits 15

Contact 16

In many stages of chemical processes, optek photometers help to ensure optimum system performance.

optek is the world's leading manufacturer of inline photometric process instrumentation. With more than 30,000 installations in various applications and industries, our team provides the best in quality, consulting, support and long term performance, worldwide.

optek process photometers provide reliable and accurate industrial process control for liquids and gases. Utilizing UV, VIS, NIR and scattered light technology, optek photometers measure inline for continuous processing. Superior materials of construction make optek photometers ideal for applications in high temperature, high pressure, and corrosive process streams.

As a global partner to the chemical industry, optek offers the most advanced technologies such as superior signal amplification, inline calibration accessories, PROFIBUS® PA, and multilingual user interfaces for easy onsite operations. Our support ensures long term satisfaction with programs like "SpeedParts" and "SwapRepair" to provide our customers sustainable operations and minimized downtime at the lowest cost of ownership.

Optimize your process with optek



inline control

04 | Halogen Concentration



optek C4000 Photometric Converter

optek provides high performance inline photometric process analyzers to the chemical industry. Installed at strategic points within the process, (inlet pipes, outlet tubes, in tail gas of reactors or in waste water streams) these analyzers provide an excellent return on investment.

Chlorine Concentration

Chlorine plays a significant part in the production of chemicals, pharmaceuticals, disinfectants, bleaching agents and insecticides. optek process analyzers provide reliable and repeatable chlorine measurements inline. These chlorine concentration measurements are performed in real-time without the need for hazardous sampling.

Measurements are possible in low and high percent ranges for gaseous phase processes, and ppm levels for liquid phase processes. Available options include high pressure, high temperature, ATEX and FM hazardous area classifications.

Measurements of other halogens like fluorine, bromine and iodine can also be achieved in gaseous and liquid phases.

Measurement

optek dual channel sensors compensate for background turbidity or other media constituents automatically using a secondary wavelength. The signals from other instruments measuring temperature or pressure are recommended to be used directly as compensation for the raw gaseous halogen concentration. The optek C4000 converter processes up to two mA-inputs, displaying the compensated signal and transmitting it via four mA-outputs or PROFIBUS® PA.



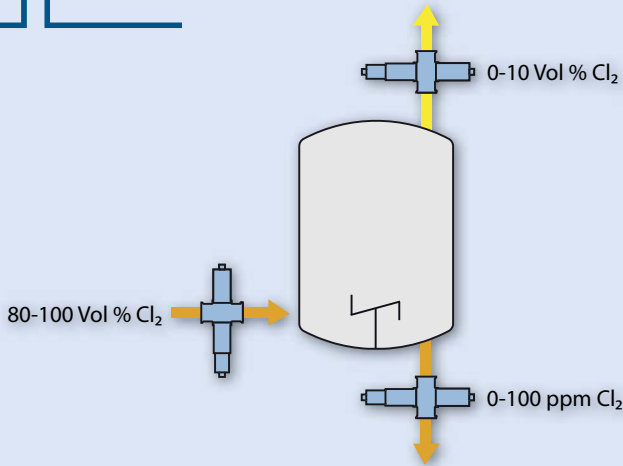

As shown in the above illustration, the chlorine is measured in the inlet of the reactor to determine the actual concentration. In the exhaust outlet, the chlorine concentration can be monitored in the gaseous phase for legal reasons and to prevent excess emissions to the atmosphere. A sensor installed in a bypass or outlet line determines the actual concentration of the chlorine in the liquid phase. Monitoring these three points ensures the highest process performance, which minimizes product losses and reduces emissions.

Due to the very aggressive chemical medium, wetted parts of the analyzer are manufactured of corrosion resistant materials like titanium, TFM, sapphire windows and fluoroelastomer O-Rings. These materials are proven to withstand highly corrosive media like wet chlorine in numerous installations.

Improve Efficiency

Using optek sensors in chemical plants provides real-time monitoring of halogens from high to low concentrations in gaseous and liquid phases.

The ability to monitor exhaust gases prevents pollution of the atmosphere while reducing the consumption and excess emissions of chlorine in chlorination reactions.

Controlling the feed rate to the reactor (chlorinator) in a dynamic control loop maximizes production efficiency and minimizes sample preparation costs.



optek AF26-EX Dual Channel Absorption Sensor

06 | Filter Control

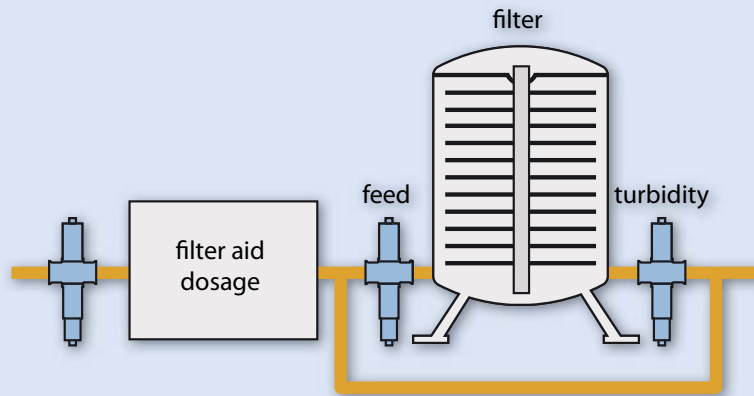

Many processes require filtration to clarify the product. Normally, filtration proceeds from coarse filtration by means of separators, decanters, or settling tanks to a final polishing by diatomaceous earth (DE) or other precoat media filters.

To control product clarity, a turbidimeter can be installed at the start of the filtration process and in between each filtering step. If product turbidity reaches an unacceptable level, the flow can be automatically recirculated or switched to an alternate filter.

Effective Filtration

optek photometers can monitor and control filter media dosing to ensure uniform precoat feed. This reduces filter media usage and extends the filter run by dosing only the amount of media necessary for effective filtration. Excessive amounts of filter media reduce the effective filtration time and increase product losses and process downtime.

The use of optek inline sensors greatly reduces the risk of equipment failure and operator error. This avoids costly refiltering, downtime, and poor product quality. optek sensors ensure that proper clarity is achieved before transferring the product to the next process stage.

Feed Stream

In addition to filtrate monitors, many large-scale processors implement an AF16-N NIR absorption sensor on the precoat side of the filter. This NIR turbidimeter measures total suspended solids in real-time allowing operators to control filter media dosing based on need rather than flow rate. Continuous monitoring of filter media addition allows accurate control of precoat concentration to ensure proper cake thickness and uniformity. This optimizes the use of filter media while extending filter runs. As the precoat media is deposited, filtrate clears up gradually. The moment the sensor detects the filtrate has achieved acceptable clarity, the converter signals the filter controller to switch from precoating to filtering operation.

The AF16-N sensor is also used to detect heavy solids carryover from storage tanks or prefiltration failure. Upon reaching the user defined high turbidity level, the filter can be switched to a recycle mode and incoming product is diverted to a settling tank, separator or to be refiltered. This will prevent filter "blinding" and provide extended use of the filter.

Backwash Optimization

An inline sensor can also be used to optimize filter backwash process by measuring the turbidity in the water, saving time, energy and water usage.

optek C4000 Photometric Converter



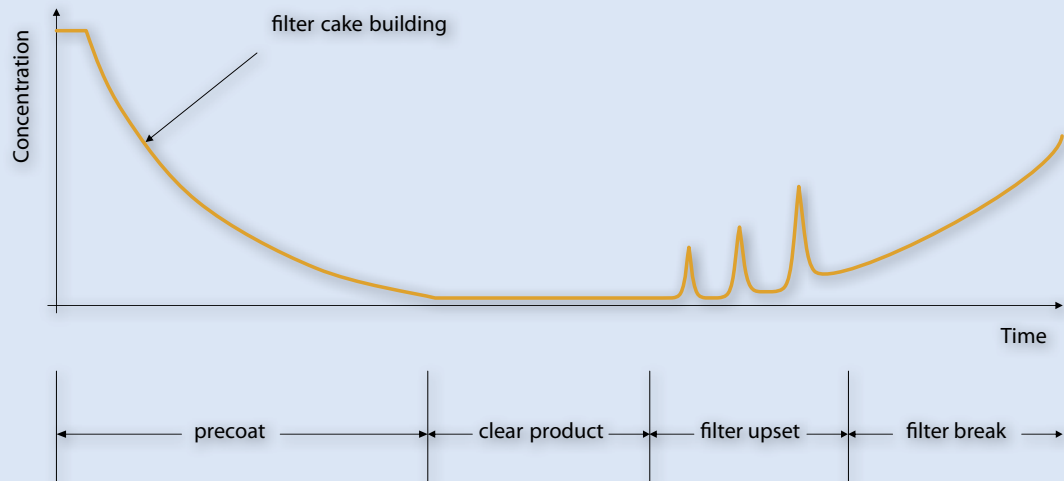

Filtrate Stream

To ensure product quality, it is necessary to measure and control turbidity at the filter outlet. An optek TF16-N scattered light turbidimeter precisely monitors very low concentrations of suspended solids from 0 – 0.5 to 0 – 500 PPM or 0 – 0.2 to 0 – 200 FTU to achieve the desired clarity of the product.

Installing an inline turbidimeter on the filtrate stream allows the automatic diversion of the filtrate to recirculation until the product clarity is improved to an acceptable level. This reduces time and improves filtration performance.

Installed directly inline, optek turbidimeters optimize filter performance and immediately detect filter upsets or breaks. These turbidimeters also greatly reduce or eliminate the amount of sampling and lab analysis performed for quality assurance.

Quality Control

Proven to be a valuable tool for process control and quality assurance, optek turbidimeters ensure that product clarity is consistently maintained. Reducing product losses, increasing filtration capacity and optimizing the use of filter media are only a few of the benefits optek inline sensors provide.



optek TF16-EX-N Scattered Light Dual Channel Turbidity Sensor

08 | Color and Concentration

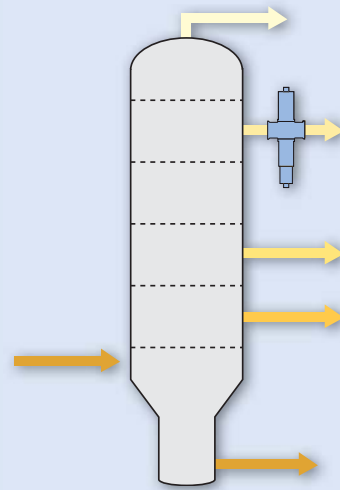

Color Measurements

Process color measurements of liquids are critical in maintaining precise process control and meeting product quality specifications. Color changes indicate other process variables such as overheating, dilution ratios, dissolved impurities and finished product appearance. Monitoring color inline using optek photometers enables precise, real-time control of color dosing, color removal, or color avoidance.

Typically, process color measurements are made by taking samples from the process piping and analyzing them in a lab either visually, or using a laboratory analyzer. optek colorimeters can immediately detect color changes in process liquids directly in the pipeline. A focused beam of light passes from the lamp through the process medium and is partially absorbed, changing its intensity. This absorption is wavelength dependent and an indication of the fluid color (i.e. yellowness).

Changes in color are detected by the sensor and converted to a signal reading. Using the C4000 converter, the measured value is easily correlated to any required unit, such as APHA/HAZEN, Saybolt, ASTM, or others. The converter displays the measurement locally, and transmits the signal to a PLC or DCS using analog outputs or PROFIBUS® PA.

Concentration Measurement

The measurement is represented in Concentration Units (CU) at a given wavelength and relates to the concentration of the constituents in question that interact with the light. The choice of narrow band-pass filters at the detector, and the proper optical path length, determine the accuracy and sensitivity of the measurement. Overall, the smaller the wavelength band-pass and the longer the optical path length, the more sensitive the measurement becomes.

Process Optimization

The detection of impurities, reduction of product losses, and the real-time assurance of product quality can be obtained by the use of inline colorimeters. In addition, these analyzers greatly reduce laboratory and production costs, eliminate human error and prevent environmental contamination.



optek AF26-EX-HT Dual Channel Absorption Sensor

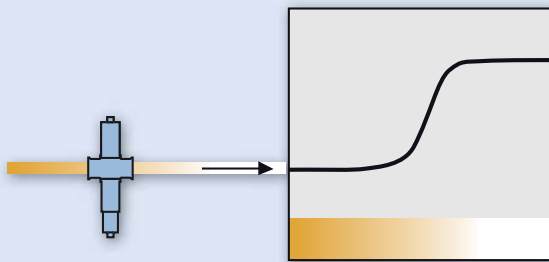

Typical Applications

- Color scales (APHA/HAZEN/Pt-Co, ASTM, Saybolt, Gardner®, and other scales)
- Chlorine dioxide
- Transition metals (nickel, copper, chromium, iron, cobalt, manganese)
- Color dosing and decolorization control
- Leak detection/carryover
- Product interface and dosing/blending control
- Distillation control
- Quality control in solvents (APHA/HAZEN/Pt-Co, ppm iron)
- Concentration measurements of colored additives and catalysts (i.e. iron in HCl)
- Galvanic plating operations (nickel plating)
- Copper sulfite
- Water/solvent ratio measurement
- Hypochlorite

optek C4000 Photometric Converter



C4000 Benefits

- Lifetime factory calibration for scattered light sensors
- Process control functions via Remote or PROFIBUS® PA
- Integrated data logger for quality control
- Secondary zero for additional offset and slope function
- User defined units (i.e. APHA, Hazen, Saybolt, Gardner®, ASTM, etc.)
- 7 menu languages selectable: German, English, French, Dutch, Spanish, Portuguese and Russian
- Flameproof housing available

10 | Condensate and Cooling Water

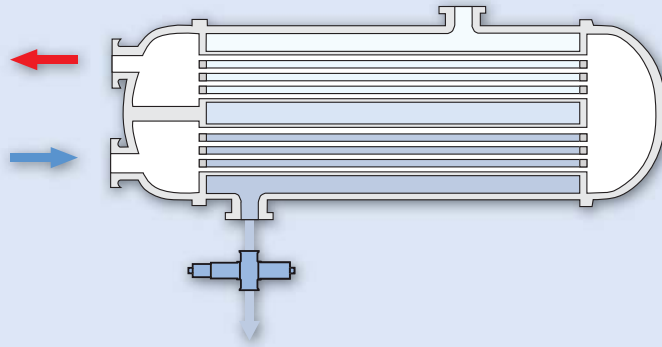

Heat Exchanger Leak Detection

Heat exchanger leak detection is an important standard application for many processors. Companies in all industries increasingly demand the measurement of oils, aromatics, or undissolved hydrocarbons in the ppm range. For this purpose, optek inline photometers have been proven worldwide as a reliable solution.

Trace oil in water detection provides advanced warning of oil contamination in water or condensate streams. optek TF16-N scattered light turbidimeters can easily detect trace contamination in heat exchanger cooling, heating and reclaim lines.

By using optek photometers in heat exchanger cooling/heating lines, a pinhole leak can be detected and repairs can be made before an expensive breakdown occurs. Also, operating costs are reduced because heat exchanger maintenance can be scheduled to minimize process downtime. This ensures proper operation of the heat exchanger and reduces the risk of bacterial growth in the heating/cooling system.

Condensate

optek photometers ensure that condensate is free from contaminants allowing it to be reused for boiler feed or other processes. This has proven to be an extremely beneficial process improvement, reducing water usage, treatment chemicals, and wastewater costs.

Carryover

There is a chance of carryover in any area where water is used to heat or cool the process stream. An optek inline photometer is an excellent tool for immediate detection of process contaminants.

In applications where the process stream consists of undissolved oil or solids, an optek TF16-N scattered light turbidimeter can detect the total particle content. By measuring in the Near Infrared (NIR) the measurement will not be affected by color or color changes.



optek TF16-EX-HT-N
Scattered Light Dual Channel
Turbidity Sensor



optek Stainless Steel Housing
with C4000 Converter

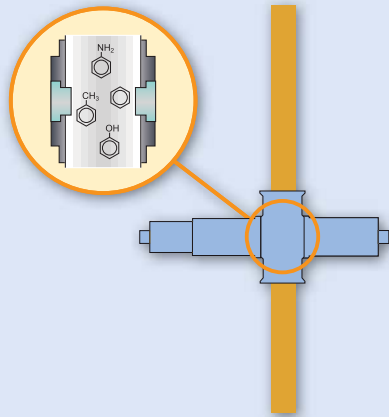

Detecting contamination in other ways, such as UV or color (yellowness) may also be advantageous for dissolved hydrocarbons, oils or aromatics. This is especially true for processors who are reusing condensate or reboiler to conserve energy, water and chemical usage.

Inline Monitoring

Using continuous inline sensors, carryover can be detected and isolated before complete failure occurs. optek process photometers help to protect the process and get the most out of valuable utilities. Easy to install and implement, optek photometers provide a rapid return on investment.

Protection of equipment and the detection of leaks or carryover are possible using optek process photometers. Additionally, the reduction of water usage, contamination risks, heat exchanger downtime, and energy consumption are just a few of the benefits using optek inline sensors.



optek C4000 Photometric Converter



optek AF46-EX-HT Dual Channel UV Absorption Sensor

12 | Phase Separation

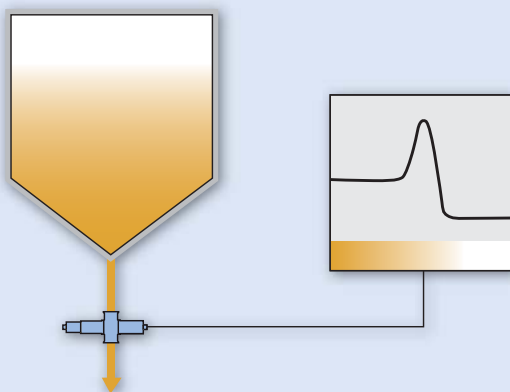

The extraction of high-cost products from an aqueous layer to an organic layer (or vice versa), or salting-in/salting-out processes, are very common and important procedures in the chemical industry.

Monitor Phase Separations

After settling of the mixture occurs in a batch reactor, the aqueous phase is separated from the organic phase. This process can be monitored easily with an optek AF26 dual channel absorption sensor at the reactor outlet to ensure separation with high precision. Each liquid phase shows differences in absorbing light. This technique allows optimization of separation processes and at the same time minimizes product loss and realizes significant cost savings.

Automation

optek AF16 or AF26 sensors reduce costs by measuring color or turbidity directly in the process line. There is no need for sight glass monitoring by production personnel, in turn eliminating losses due to manually switching valves and human error.



optek AF26 Dual Channel Absorption Sensor



optek C4000 Photometric Converter

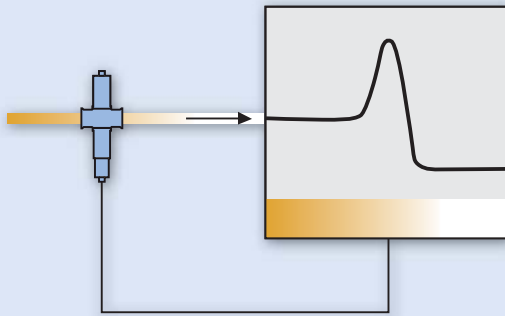

Increase Product Quality

Product losses are no longer an issue when detecting different phases inline. Faster product changeovers are possible with continuous optek inline measurements. Fast response time and use of relays for automatic diversion ensures product quality and improves process control.

optek offers a customized solution based on your process media and automation requirements. optek also manages phase separations in a wide range of wavelengths, from Ultraviolet (UV) to Visible (VIS) and Near Infrared (NIR). Precise, real-time measurements are made inline with optional Ex-proof sensors.

The water phase can be detected reliably, ensuring a separation that is independent of the composition of the organic phase.

optek inline sensors detect the most subtle changes in your process so the appropriate action can be made by the control system. Enabling the data logger feature in the C4000 converter allows plants to collect real-time process data for QA/QC. Monitoring phase separations inline and in real-time with optek sensors provides a rapid return on investment.



optek C4000 Photometric Converter



optek Calibration Accessories (NIST-traceable)

14 | Principles of Measurement

Sensor AF16

VIS- and NIR-Absorption, single channel concentration and color measurement

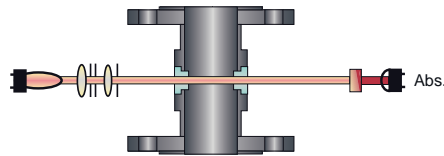

Sensor AF26

VIS-Absorption, dual channel color measurement with turbidity compensation

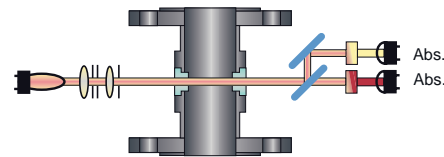

Sensor AF45

UV-Absorption, single channel concentration measurement with compensation of lamp intensity

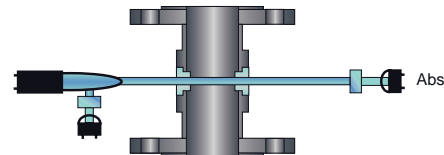

Sensor AF46

UV-Absorption, dual channel concentration measurement with compensation of lamp intensity and background turbidity

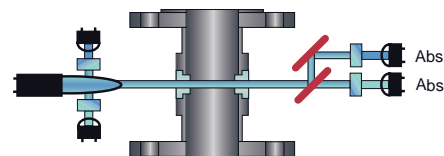

Sensor TF16

11° Scattered Light and NIR-Absorption, dual channel turbidity measurement

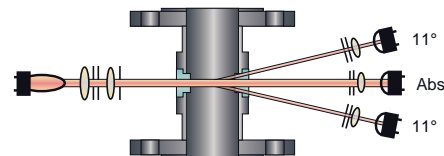



Technical Aspects

- Temperatures up to 240 °C (464 °F)
- Pressures up to 325 bar (4713 psi)
- Line size ¼" to 6"
- FM and ATEX approved for hazardous locations
- Optical path length (OPL) from 1 to 1000 mm (depending on sensor)
- High resistivity materials to withstand the harshest process environments
- Reference filter for inprocess "calibration" checks (NIST-traceable)
- Universal C4000 converter for all optek sensors (up to two sensors with one converter)
- Configurable software allows easy correlation to almost any unit of measure (ppm, %, mg/L, APHA / HAZEN / Pt-Co, Saybolt, Gardner®, ASTM, etc.)
- PROFIBUS® PA available
- Certification ISO 9001:2000, ATEX, FM, PED, CE, HPO



Flameproof housing Ex d for optek C4000 converter



Interested in Foundation Fieldbus Applications?

Just ask optek!



Germany

optek-Danulat GmbH
Emscherbruchallee 2
45356 Essen / Germany
Phone: +49 201 63409 0
Fax: +49 201 63409 999
E-Mail: info@optek.de



USA

optek-Danulat Inc.
N118 W18748 Bunsen Drive
Germantown WI 53022 / USA
Phone: +1 262 437 3600
Toll free call: +1 800 371 4288
Fax: +1 262 437 3699
E-Mail: info@optek.com



Netherlands

optek-Danulat bv
Grote Brugse Grintweg 12a
4005 AH Tiel / Netherlands
Phone: +31 344 683800
Fax: +31 344 653950
E-Mail: info@optek.nl



Singapore

optek-Danulat Pte. Ltd.
25 Int'l Business Park
#05-109-f German Centre
Singapore 609916
Phone: +65 6562 8292
Fax: +65 6562 8293
E-Mail: info@optek.com.sg



Russian Federation

optek-Danulat GmbH
Kolomjazhskij Pr. 33-A
Office 911
197341 St.-Petersburg
Phone: +7 812 380 72 47
Fax: +7 812 380 72 05
E-Mail: info@optek-danulat.ru



China

Room 718 Building 1
No.88 Keyuan Road
Pudong Zhangjiang
Shanghai, China 201203
Phone: +86 13501613476

中国

上海市浦东张江
科苑路88号1号
楼718室
邮编: 201203
电话: +86 13501613476

Российская Федерация

Офис в России
Коломяжский пр., 33-А
Комната 911
197341 С-Петербург
Тел.: +7 812 380 72 47
Факс: +7 812 380 72 05
E-mail: info@optek-danulat.ru

Please visit our website for contacts of our local distributors in other countries.

www.optek.com